



STEEL  
WINDOW  
ASSOCIATION

# FACT SHEET

STANDARD METAL WINDOWS  
(SMW)

## STANDARD METAL WINDOWS (SMW)

Standard Metal Window (SMW) 'F' series window range has been manufactured since the 1890s, and is a stylish solution for a number of aesthetically sensitive historical projects.

Available as single or double glazed, SMW windows are primarily used today for bespoke replacement work in Conservation Areas and Listed Buildings, where a suitable geometric match is required.

These windows can be glazed using an external glazing bead, putty (not advised with double glazing) or silicone fronted for an authentic appearance. These frames are galvanised and can be powder coated for low maintenance. They use single point locking, an external hinge and a simple weather stripping detail. Each frame is made from recycled steel to add a further eco-friendly credential.

Shaped frames are also possible and so gables, raked heads and arches are not a problem for our members. Even curved on plan windows are possible and so traditional 'suntrap' bay windows can be manufactured. The frames glazed using single glazing can have traditional genuine leaded lights and can also have stained glass designs. Double glazed units can be manufactured with clear glass or decorations can be applied such as rectangle or diamond leaded, coloured film, horizontal or Georgian applied bars. Obscured glass is also available in a variety of options.



STANDARD METAL WINDOWS (SMW)

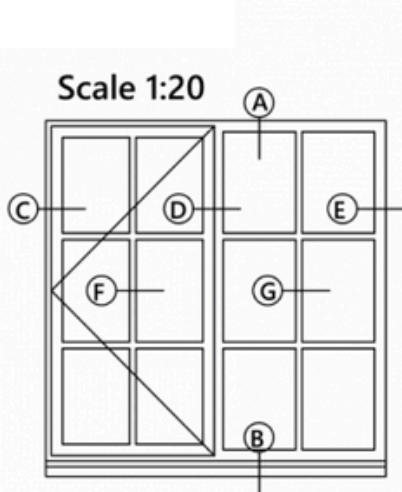

Scale 1:2

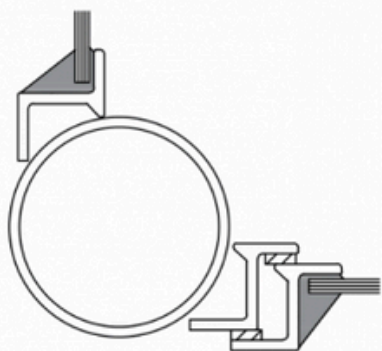
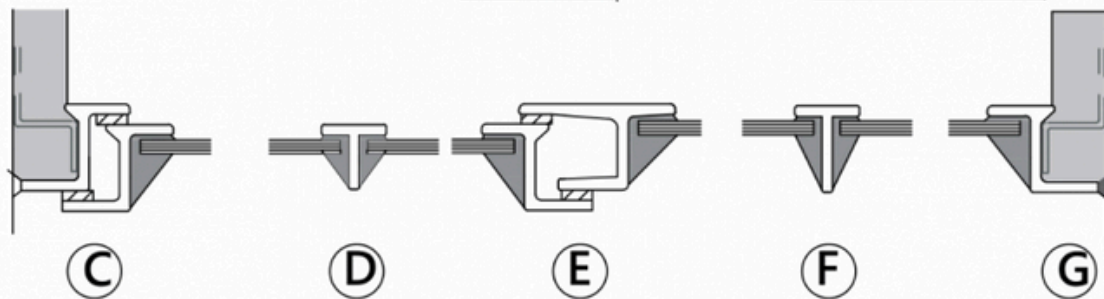
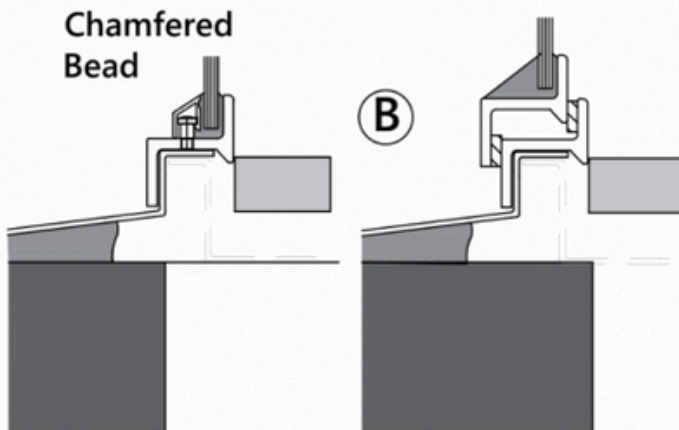
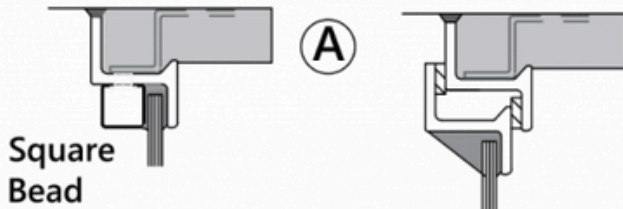

Typical Circular hollow section tubular mullion coupling

Scale 1:2

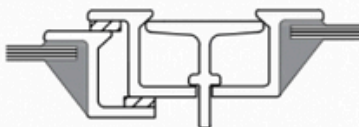

K11 Mullion Coupling

K12  
Weatherdrip  
Transom  
Coupling

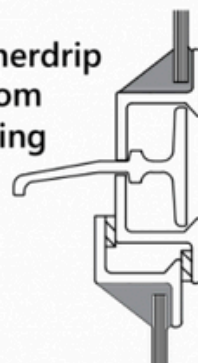

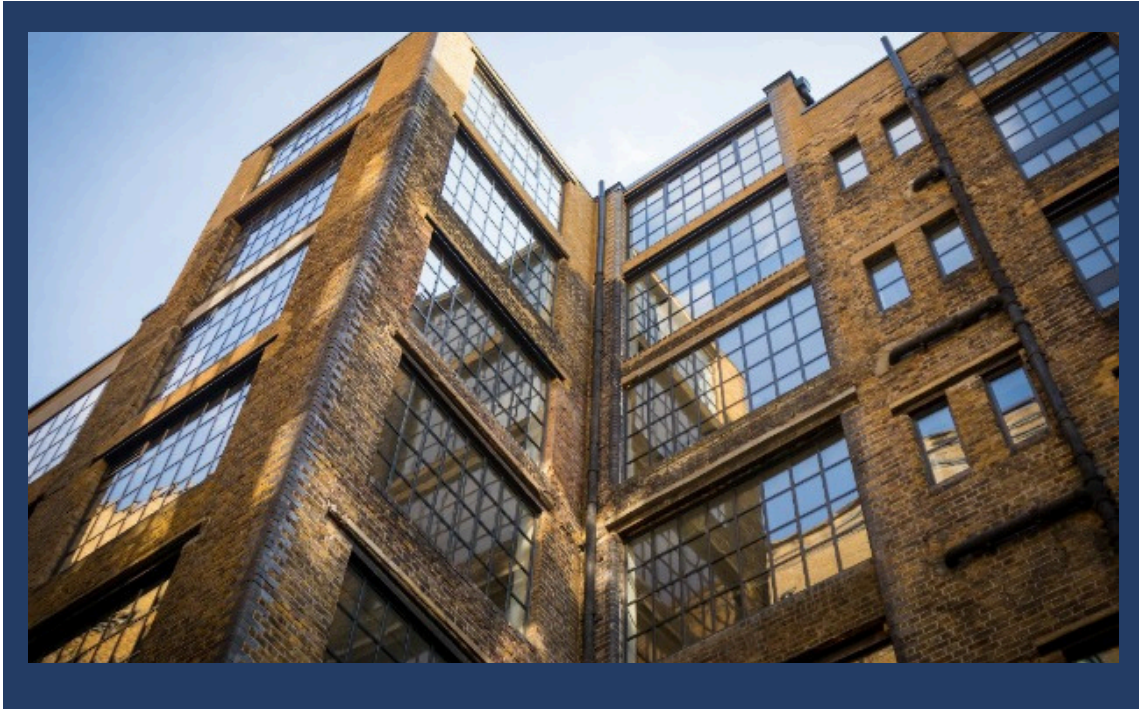

The Steel Window Association represents the great majority of UK steel window manufacturers, ranging in size from the smallest of craft-based companies that specialise in replacement and repair work, particularly on windows for Heritage buildings, through to large, multi-site companies that manufacture and install windows in literally every type of building. There is not a single steel window project of any description, anywhere in the UK, that one of the SWA members cannot handle.

All windows produced by SWA members in hot rolled steel sections to BS.6510 are protected by the hot dip galvanizing process in accordance with BS EN ISO 1461. Cold formed steel section windows are also available, and all steel section windows can be supplied with a decorative finish available in a range of colours. This process, in which polyester powder is electrostatically applied then heat fused under factory-controlled conditions to BS EN 13438, gives a high quality, attractive and durable finish with a life expectancy of at least 15 years.

The Steel Window Association supports its member companies with a wide-ranging service relating to product development, market research and promotion and the SWA helps ensure that each member operates to the highest industry standards. Every contract undertaken has the personal attention of senior management and SWA member companies operate established and flexible services in window design, manufacture, installation and repair and refurbishment.

