

Product Code MA419 & MA419/V	Product Description MAGNUM RESTRICTOR	Product Type SWA RESTRICTOR
Test Specification Ref. EN14609 / EN948	Equipment Used IN HOUSE TEST RIG	Other Details

TEST DESCRIPTION

TEST LOAD TO SEE STRENGTH OF RESTRICTOR ARMS - LOAD REF 350N HOLD FOR 60 SEC

Clause	Performance Requirements	Results	Pass	Fail
	EN14609 / EN948 - 350n FOR 60 SEC	1000N / 100kg	✓	

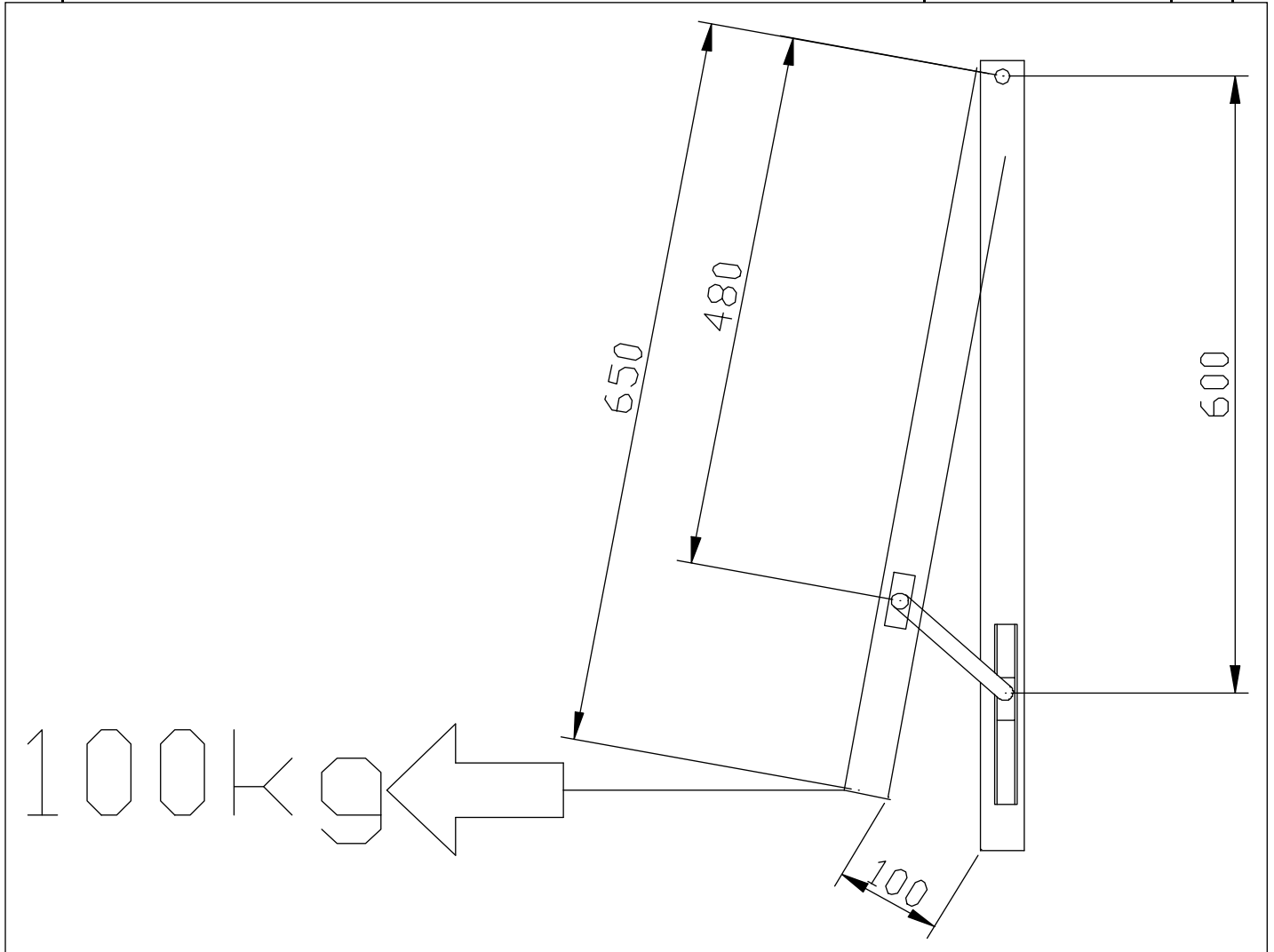

Comments A MA419 restrictor was setup on steel section as above to test the strength, the load was applied at 650mm centre and reached 100kg (1000N) and held for over 60 sec without any deformation occurring

Date Test Started	Date Test Finished	Tested By	Approved By	Results Reviewed By	Signed	Date
15.09.09	15.09.09	T.CORBETT		J.BARRETT	T. Corbett.	15.09.09

